

THE INTERNATIONAL RESEARCH GROUP ON WOOD PROTECTION

**Guidelines for the preparation of a Poster Paper and Poster
Presentation at an IRG Scientific Conference**

NB

Please note that papers received after the deadline 1 March 2019 will be posted on the website (Compendium) but the opportunity to make an oral presentation will be at the discretion of the Scientific Programme Committee chair. These papers may be presented as posters at the meeting. Deadline for submitting extended abstract or short papers for poster presentations is 1 April 2019.

**IRG SECRETARIAT
Box 5604
SE-114 86 Stockholm
Sweden
www.irg-wp.com**

Dear author of the IRG paper!

Allocation of the papers to different sections is one of the most challenging tasks for the Scientific Programme Committee (SPC). In order to prepare good programme for the upcoming conference, we would like to ask you for assistance. Please tick, the most appropriate Working Party, where your paper fits most. SPC will try to consider your opinion.

Section 1. Biology	WP 1.1. Soft rot, bacteria, bluestain and moulds	<input type="checkbox"/>
	WP 1.2. Basidiomycetes	<input type="checkbox"/>
	WP 1.3. Insect biology and testing	<input type="checkbox"/>
	WP 1.4. Natural durability	<input type="checkbox"/>
	WP 1.5. Marine	<input type="checkbox"/>
	WP 1.6. Cultural Artefact Protection	<input type="checkbox"/>
Section 2. Test Methodology and Assessment	WP 2.1. Prediction of service life	<input type="checkbox"/>
	WP 2.2. Microbial test methodology	<input type="checkbox"/>
	WP 2.3. Chemical/physical analysis	<input type="checkbox"/>
	WP 2.4. International Standardisation	<input type="checkbox"/>
Section 3. Wood Protecting Chemicals	WP 3.1. Inorganic preservatives	<input type="checkbox"/>
	WP 3.2. Organic preservatives	<input type="checkbox"/>
	WP 3.3. Performance - lab & field tests	<input type="checkbox"/>
	WP 3.4. Fire retardants	<input type="checkbox"/>
Section 4. Processes and Properties	WP 4.1. Chemical wood modification	<input type="checkbox"/>
	WP 4.2. Wood composites, WPCs and Engineered wood products	<input type="checkbox"/>
	WP 4.3. Treating processes & treatability of timber	<input type="checkbox"/>
	WP 4.4. Coatings, hydrophobic treatments and surface aspects	<input type="checkbox"/>
	WP 4.5. Thermal wood modification	<input type="checkbox"/>
	WP 4.6. Fire protection	<input type="checkbox"/>
	WP 4.7. Protection by design	<input type="checkbox"/>
Section 5. Sustainability and Environment	WP 5.1. Environment	<input type="checkbox"/>
	WP 5.2. Sustainability	<input type="checkbox"/>

This paper is intended for:

- Short oral (3 min., 1-3 slides) + poster presentation
 Poster presentation only

This poster paper will most probably be presented by:

.....(name)

.....(email address)

This paper will be listed as part of the Proceedings according to Thomson-Reuters index system.

OVERVIEW OF PREPARING A POSTER AND A POSTER PAPER

A poster is a graphically based approach to presenting research. The standard format of a poster should generally follow the same format as the full scientific presentation and generally includes: Title/Authors/Affiliations, Introduction, Materials and Methods (Experimental Design or Procedures), Results and Discussion, Conclusions/Recommendations; A poster should be concise in wording and should not contain all the detailed information about the subject. You should aim to use the poster as a means for generating active discussion of the research studies. Scientific posters should stimulate interest rather than provide a detailed presentation. Since there will be multiple posters that will be shown, you need to make sure to use more “visuals” (graphs, photographs, schematics, maps, etc.) to make your poster interesting and visually attractive to the viewers.

A poster shall always be accompanied by a poster paper shaped as a 2-4 pages extended abstract based on the template and Guidelines for the preparation of a full scientific paper IRG/WP 18-60447(see also pages 5-8 in this document).

General guidelines:

- The relevance of the poster for IRG meetings must be germane to wood protection research or wood protection industry.
- Plan the layout of your poster beforehand. Place the title/Authors/Affiliations at the top. Start with the Introduction at the upper left, finish with the conclusions/recommendations at the lower right, with Materials and Methods (Experimental Design or Procedures), Results and Discussion filling the central space.
- Use short sentences, simple words, and bullets to illustrate your points.
- Text should be broken up by including visuals, such as graphs, photographs, schematics, maps, etc. along with colour decorations
- Self-explanatory graphics should dominate the poster. The success of a poster directly relates to the clarity of your illustrations and tables!
- Avoid using jargon, acronyms, or unusual abbreviations.
- The poster (text and graphics) should be easily readable from a distance of about 2 metres. As a thumb rule, the text should be readable if the poster is printed out on an A4 sheet (e.g. Arial >24 points).

Title: Title should be in large fonts and attract potential viewers. If possible, include author names, institute logos or affiliations in smaller size and put in below the title.

Introduction: Precisely present the issue or question or topic to get your viewers interested while using the absolute minimum of background information and definitions. Be sure to include objectives of your study at the end of your introduction.

Materials and Methods: Be short, but precise. State what study design you used and define experimental design. Provide a case definition, if applicable. Mention statistical, laboratory and other methods that were used.

Results and Discussion: Briefly provide descriptive results. Present data that more specifically addresses the hypothesis and refer to supporting charts or images. Tables and graphs should stand on their own. Discuss your results in precise and concise way.

Conclusion and/or Recommendations: Comment on main results and demonstrate why they are conclusive and interesting. What are your recommendations for future studies?

Making the poster

- Give yourself ample time to prepare a poster, and generally plan for about 1-2 weeks ahead.
- Make it obvious to the viewer how to progressively view the poster. The poster generally should read from left to right, and top to bottom. Numbering the individuals panels, or connecting them with arrows, is a standard "guidance system" (An Example as shown below).
- Usually a presentation software such as PowerPoint will be used. Format your PowerPoint slide on the size you'll like to have it printed (e.g. 90x130 cm) by using the menu data -> format page. You can insert your text and graphics directly on that slide or copy-paste it from a Word document or a PowerPoint slide.
- Print the poster in an A4 format to check for layout, colors, font size and spelling errors before printing it in large size.
- After the poster is printed in large format, changes are no longer possible.
- **It is recommended to have some handouts of your poster for distribution during the session.**

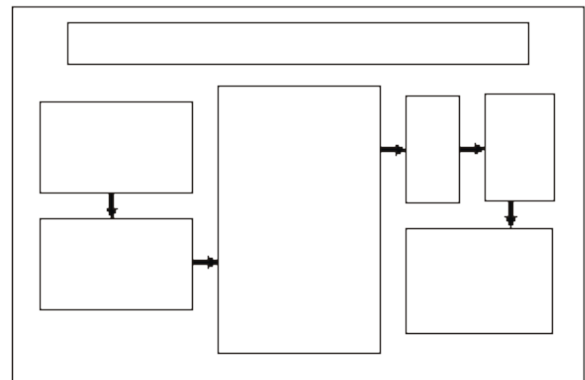
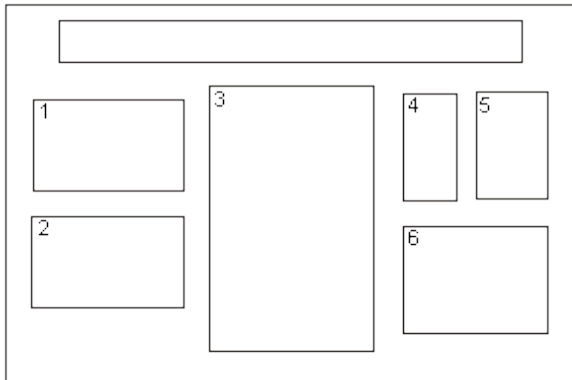

THE INTERNATIONAL RESEARCH GROUP ON WOOD PROTECTION

Section Y

VVVVVVVVVV

Title of paper

Author(s)*

Organisation, University etc

Department etc

Address

Postcode, city, country

*Organisation etc for co-authors (if other than for first author)

Poster paper prepared for the IRG50 Scientific Conference on Wood Protection
Quebec City, Quebec, Canada
12-16 May 2019

Disclaimer

The opinions expressed in this document are those of the author(s) and are not necessarily the opinions or policy of the IRG Organization.

**IRG SECRETARIAT
Box 5604
SE-114 86 Stockholm
Sweden
www.irg-wp.com**

Title of paper (Use 14 pt Times New Roman or Arial bold)

First Author¹, Second Author², Third Author³

¹ Address of first author, including affiliation, country, and e-mail address

² Same for second author

³ Same for subsequent authors

ABSTRACT

This document explains how to prepare a manuscript for an IRG Annual Meeting. Please read the instructions carefully, they are formatted according to the guidelines and can be used as a template. If possible, please prepare your manuscript using 'MS Word' word processing software. The complete document shall be submitted by e-mail to the IRG Secretariat irg@sp.se. Files might be submitted zipped when necessary. There is no need to send hard copies to the Secretariat. All pictures, tables, and figures should be embedded in the text. Top and bottom margins are 2.5 cm, right margin is 2 cm, and the left margin is 2.5 cm. Do not place any text outside of this area. If presenting for a full oral presentation, your paper can be up to approximately 20 pages long (including references), if presenting a poster with short oral presentation your paper can be up to approximately five pages long (including references). Please do not exceed these page limits. Your abstract should be between 250 to 350 words long.

Keywords: List the keywords (3-7) of the subjects covered by your paper.

1. INTRODUCTION

All manuscripts should be in English. Metric units (SI) should be used. It is assumed that the corresponding authors grant us copyright to use the manuscript in the proceedings. Should the authors use tables or figures from other publications, it is assumed that permission has been obtained to do so. To emphasize a word or a phrase, use *italics*, only use capitals or bold for the section headings.

2. ORGANISATION OF THE TEXT

Following the introduction, if appropriate to the content of the paper, please follow the structure: EXPERIMENTAL METHODS, RESULTS AND DISCUSSION, CONCLUSIONS, REFERENCES. All text styles are set in this document, body text is 12 point Times New Roman (or Arial). Main section headings are bold, left justified, and capitalised. Second level headings are left justified, bold, and lower case. Third level headings are left-justified, italics, bold and lower case.

2.1 A Second Level Heading

This is a second level heading.

2.1.1 A third level heading

This is a third level heading.

2.2 Page numbers

Centered at bottom. The title page should not be numbered.

2.3 Tables

These should be included in the text but separated from the text by a blank line above and below. A descriptive title should be given above the table in 11 pt. Times New Roman (Arial) and left-justified. Units should be given in square brackets. An example is given below (Table 1).

Table 1: Results of test

Specimen	Length [m]	Width [m]	Height [m]	Weight [kg]
1 ^a	1	1	1	1
2	2	2	2	2
3 ^b	3	3	3	3
4	4	4	4	4

^aBirch, ^bCorsican pine

2.4 Figures

Figures should be referred to in text as Fig. 1, or as (Fig. 1) and should be presented as part of the text, again leaving a blank line above and below. Use Times New Roman (Arial) 11 pt. for the figure captions. *If at all possible all figures should be embedded in the text.* Graphs must be disconnected from spreadsheets.

If this is not possible, then supply the figures on separate sheets and these will be scanned in. If this is done then please put each figure on a separate sheet of paper and identify that figure on the back of the paper. Also mark in the paper where the figure is to be included. If figures are not included in the text, then please note the page limits that apply and ensure that the number of pages of text allows for the page limit to be adhered to when the final document is prepared.

Example:

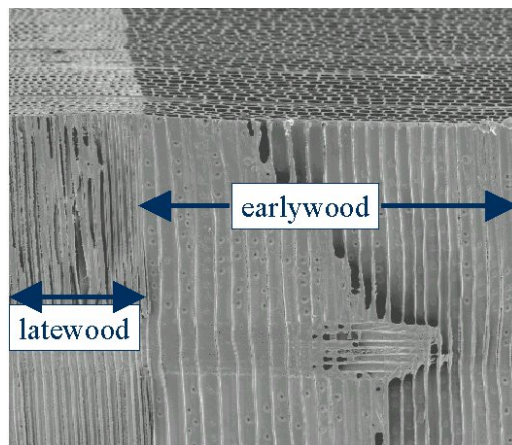

Figure 1: Scanning electron micrograph of a softwood

2.5 Equations

Equations should be referred to in the text as Eq. 1 (or Eq. 1) and should be indented five spaces. A line should be left above and below to separate the equation from the text. The equations should be numbered sequentially, with the number in brackets on the right hand side of the page.

Example:

$$a^2 = b^2 + c^2 \quad (1)$$

2.6 References

All references should contain enough information to allow a reader to find the cited materials. Do not abbreviate journal titles. Cite references in the text using the author's last name and date of publication as follows (Murphy 1990, Jones and Smith 1989, Davis *et al.* 1999). List the citations at the end of the manuscript in alphabetical order (examples given below).

3. ACKNOWLEDGEMENT

This research project has been sponsored by University Program/ABC Corporation/Government Agency. The authors would like to (thank/acknowledge/recognise) the following individuals...

4. REFERENCES

Ross, R J, DeGroot, R C, Nelson W J (1994): Technique for the non-destructive evaluation of biologically degraded wood. *Experimental Techniques*, **18**(5), 29-32.

Clausen, C A, Green III, F, Highley, T L (1991): Early detection of brown-rot in southern yellow pine using monoclonal antibodies. In: *Proceedings of the 8th International Biodeterioration and Biodegradation Symposium*, ed. H.W. Rossmore. Windsor, Ontario, pp. 412-414. Elsevier Applied Science, New York.

Jenkins, J A (1980a): *Fundamentals of Soil Mechanics*. Vol. I, John Wiley and Sons, New York.

To cite an IRG Document:

Podgorski L, Grüll G, Truskaller M, Lanvin J D, Bollmus S (2011). Wet and dry adhesion of coatings on modified and unmodified wood: influence of 18 months of natural weathering on the pull-off test and the cross-cut test results. *Proceedings IRG Annual Meeting*, IRG/WP 11-40569, 19 pp.